

GEMAN AUTOMATIC DOORS

**ΑΥΤΟΜΑΤΕΣ ΠΟΡΤΕΣ
ΑΝΕΛΚΥΣΤΗΡΩΝ**

**AUTOMATIC DOORS
FOR ELEVATORS**

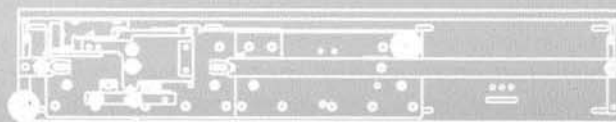

**2-ΦΥΛΛΗ
ΤΗΛΕΣΚΟΠΙΚΗ
2-PANEL
TELESCOPIC**

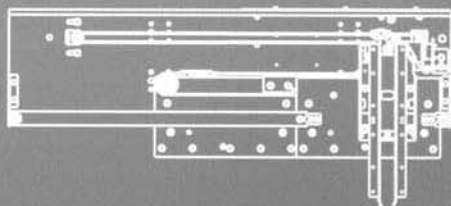
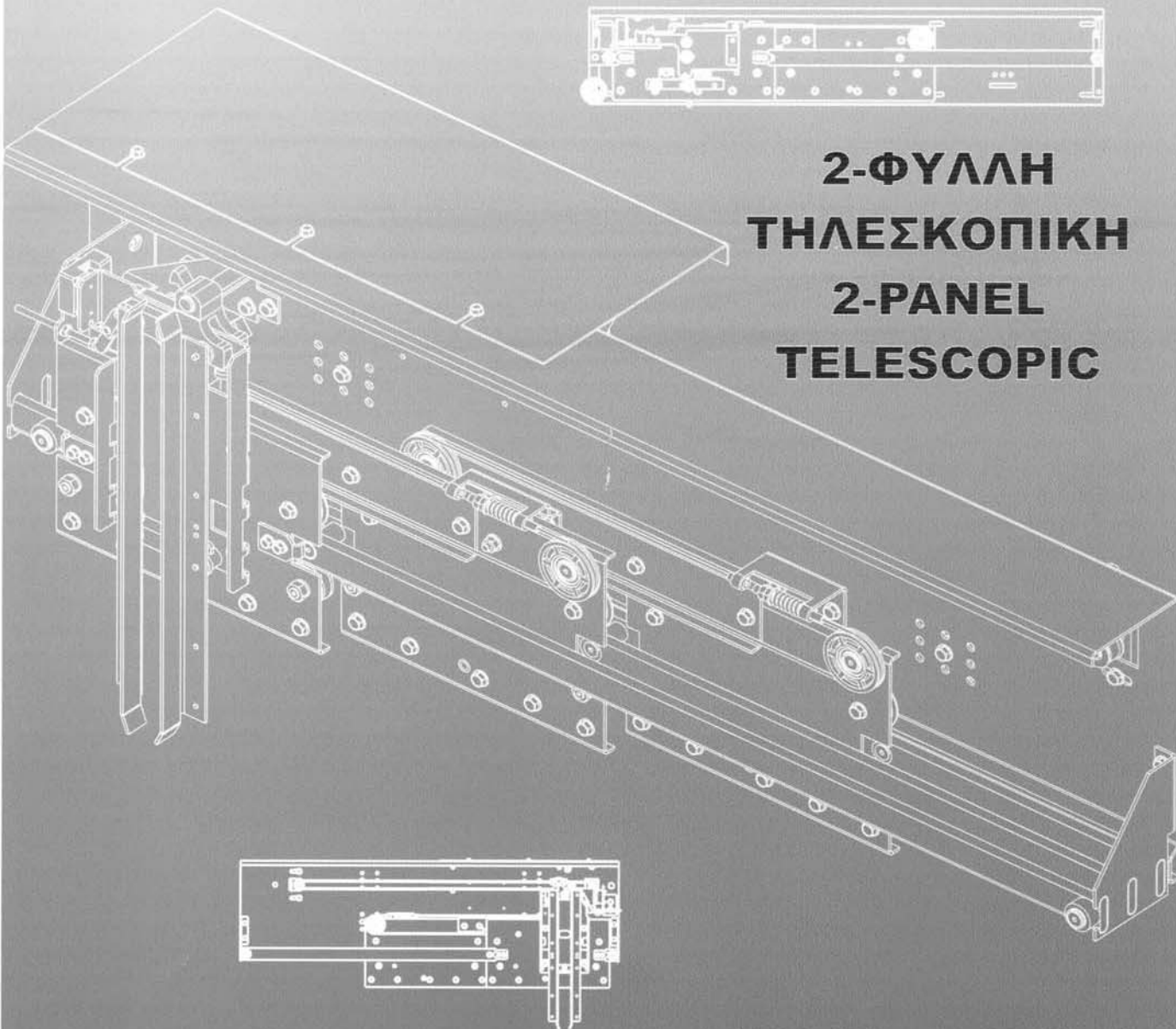

ΕΚΔΟΣΗ
ISSUE 1.25.03

ISO 9001



ΑΥΤΟΜΑΤΗ ΠΟΡΤΑ 2-ΦΥΛΛΗ ΤΗΛΕΣΚΟΠΙΚΗ
ΘΑΛΑΜΟΥ
AUTOMATIC DOOR 2-PANEL TELESCOPIC
CABIN

ΗΜΕΡΟΜΗΝΙΑ DATE
 29/4/2003
 ΣΕΛΙΔΑ PAGE
 1.1

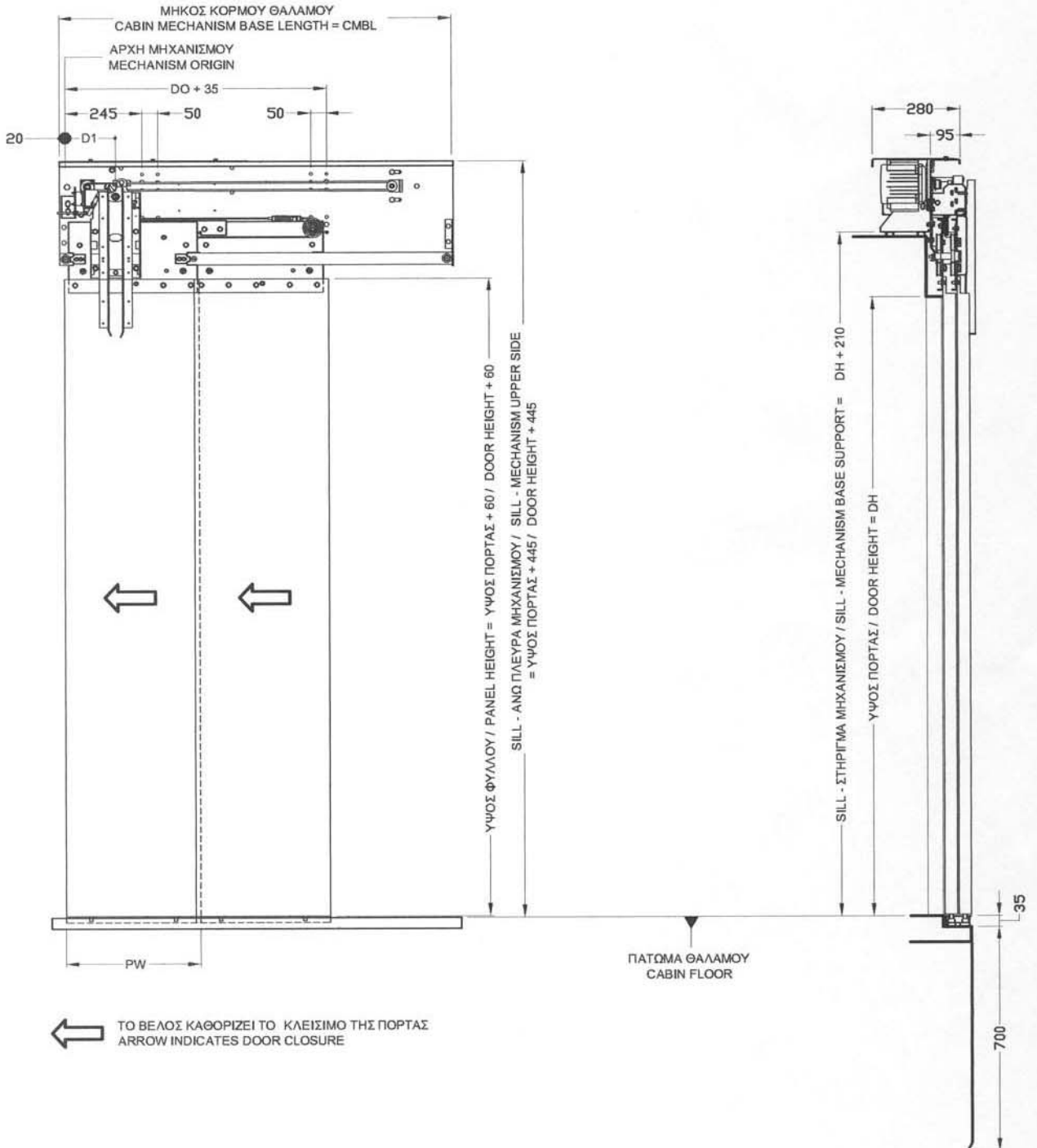

DO	600 - 1800
D1	160



ΑΥΤΟΜΑΤΗ ΠΟΡΤΑ 2-ΦΥΛΛΗ ΤΗΛΕΣΚΟΠΙΚΗ
ΟΡΟΦΟΥ

ΗΜΕΡΟΜΗΝΙΑ DATE
29/4/2003

AUTOMATIC DOOR 2-PANEL TELESCOPIC
LANDING

ΣΕΛΙΔΑ PAGE
1.2

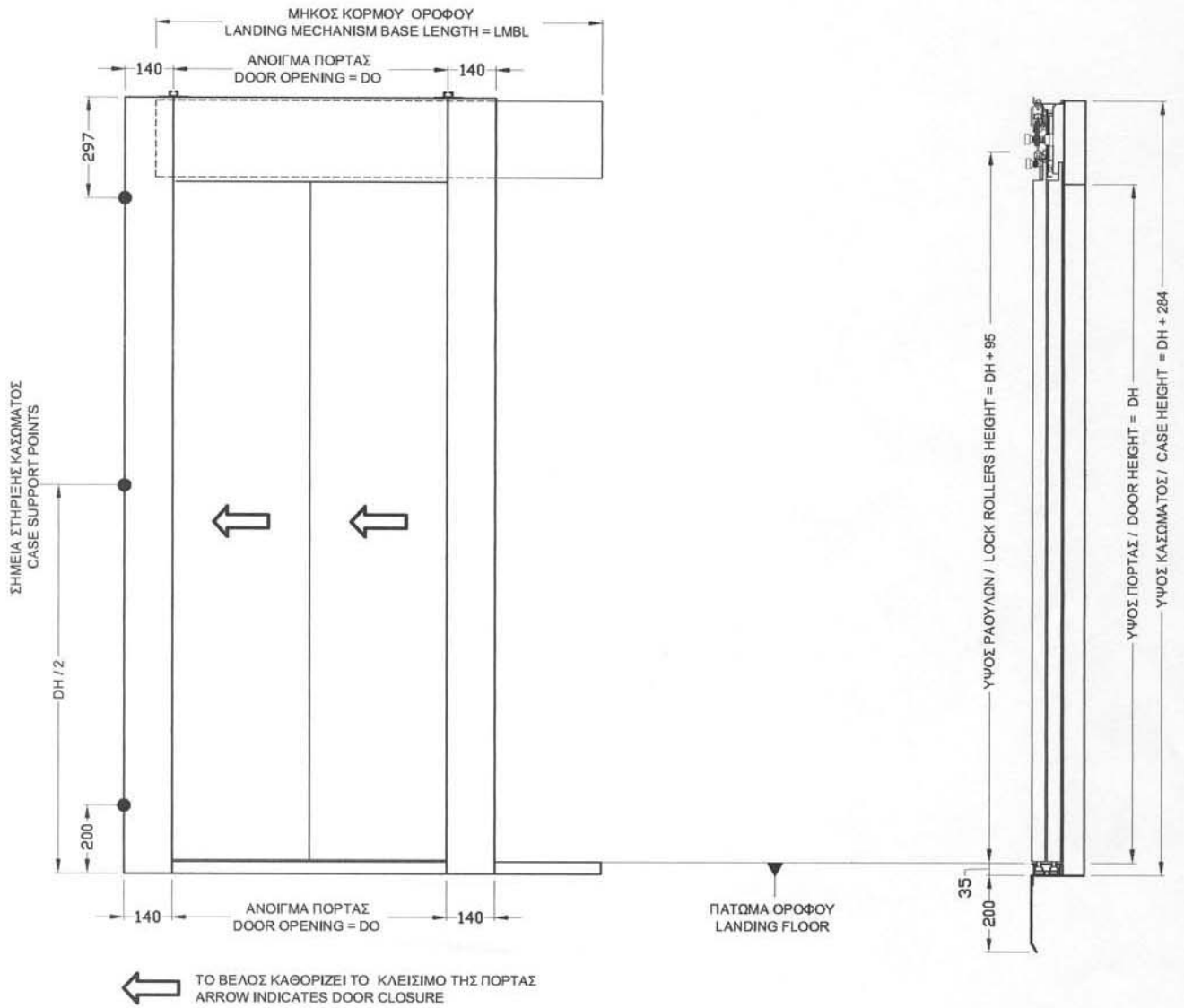



ΑΥΤΟΜΑΤΗ ΠΟΡΤΑ 2-ΦΥΛΛΗ

ΟΡΟΦΟΥ

AUTOMATIC DOOR 2-PANEL

LANDING

ΗΜΕΡΟΜΗΝΙΑ DATE

29/4/2003

ΣΕΛΙΔΑ PAGE

1.4

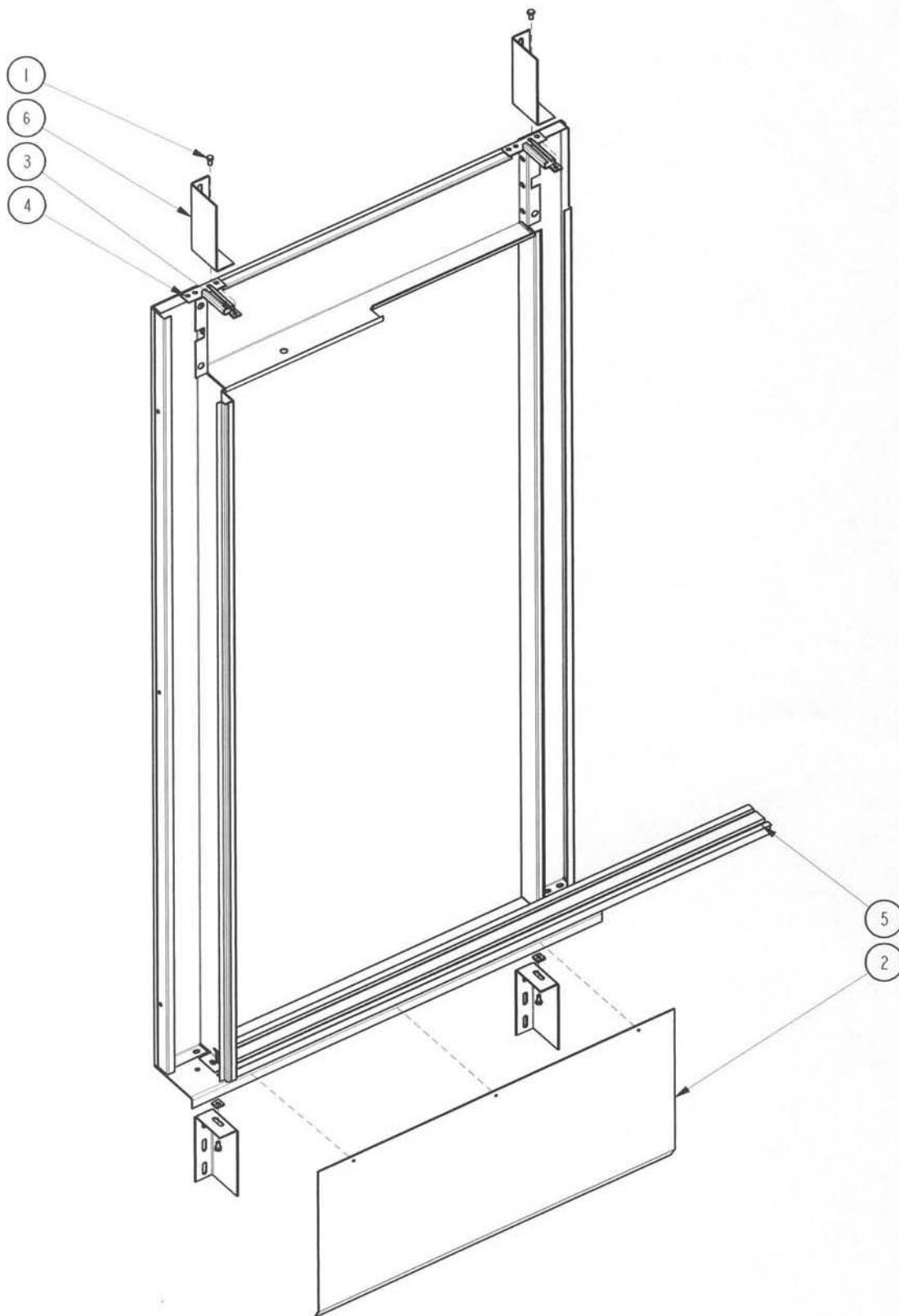



ΑΥΤΟΜΑΤΗ ΠΟΡΤΑ 2-ΦΥΛΛΗ ΤΗΛΕΣΚΟΠΙΚΗ
ΟΡΟΦΟΥ - ΘΑΛΑΜΟΥ

AUTOMATIC DOOR 2-PANEL TELESCOPIC
LANDING - CABIN

ΗΜΕΡΟΜΗΝΙΑ DATE

29/4/2003

ΣΕΛΙΔΑ PAGE

1.9

